

## SSBVF Stainless Steel Ball Valve Flanged, Class-150

HSN 84818090

### Product Description

Product : Sant Stainless Steel Ball Valve (F), SS (304)  
 Pressure/Class/Rated : Class-150  
 Body Material Cum Standard : S.S. AISI-304 (CF-8)  
 Product Description : 3 Pc Design Lever Operated  
 Type of Seat : Renewable  
 Stem : AISI-410  
 Ball : AISI-304 (CF-8)  
 Seat Ring & Gland Packing : PTFE  
 End Details : Flanges as per B 16.5 Class-150 (Drilled)



### Testing & Certification

Body Test Pressure : 30 Barg (435psig. Hyd.)  
 Seat Test Pressure : 22 barg (320psig. Hyd.)  
 Maximum Working Temp. : 225°C

Our Works' Test Certificate is furnished with every supply.

### Materials of Construction

Components	Materials	Specifications
Body, Connector	C.S.S.	ASTMA 351-CF8
Ball, Stem, Gland, Spring Washer, Lever Nut, Fasteners	S.S.	AISI-304
Seat, Gland Packing	PTFE	—
Lever	S.S.	—

### Dimensions (in mm)

Nominal Size	Nominal Size (Inches)	F
15	1/2	108±2
20	3/4	117±2
25	1	127±2
32	1.1/4	140±2
40	1.1/2	165±2
50	2	178±2
65	1/2	190±2
80	3/4	20±2
100	1	229±2

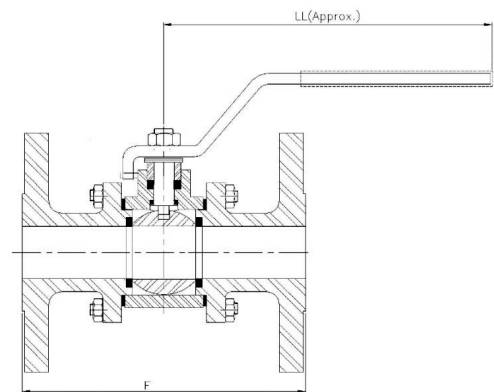

### Notes

- Product images are for illustration purposes only. Actual product may vary.
- Actual dimensions may change over time, due to continual design improvements. Please confirm before placing order.